

solutions

Industry Updates and Solutions
for Conveyor Material Handling
Applications.

Providing the World Material Handling Industry with Productive, Safe and Reliable "Complete Conveyor Solutions."

ASGCO®

Complete Conveyor Solutions

ASGCO Wash Box Solves Severe Carry-back Problem at a Major Underground Coal Mine.

PROBLEM & SOLUTION:

Since its introduction at the Electric Power Show and Conference in Rosemont Illinois in May of 2009 the ASGCO Wash Box has solved many severe carry-back problems in a wide variety of bulk material handling industries.

Most recently the Wash Box solved a severe carry-back problem at a large production underground coal mine.

The first conveyor belt the ASGCO Wash Box was installed on at this facility is 60" wide and runs at 950 FPM and delivers 3500-4000 TPH and operates approximately 20 hours per day. At these kinds of belt speeds and TPH a highly effective belt cleaning system was required.

The effectiveness of the Wash Box system using a low volume of water reduced clean up cost, premature wear and failure on rolling components and build up on return idlers causing belt mis-tracking and ultimately belt edge damage.

The ASGCO **Wash Box** is installed as a secondary belt cleaner and is designed to work on the return side of the conveyor belt. Each steel enclosed box is equipped with a combination of pressure rollers, spray bars and Razor-Back belt cleaners. It can also be customized to meet your exact needs. The nozzles apply a spray of water which softens the carry-back and lubricates to maintain effective cleaning pressure.

- **Fully Enclosed** - the Wash Box (Galvanized or Stainless Steel) system provides excellent cleaning while containing the wash waste fluid.
- **Removable Inspection and Service Door** - on each side, with wash down hose included.
- **Dual Sets of Razor-Back Secondary Cleaners** - and dry wipe.
- **Two Spray Bars, Nozzles and Valves** - soften the carry-back and provides gentle cleaning.
- **Equal Pressure** - Snub Idler provides equal pressure on both Razor-Back cleaners.
- **6" NPT Drain Pipe**

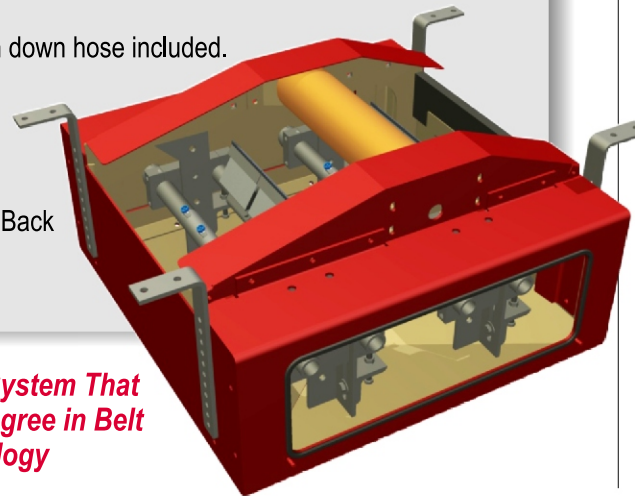

*Superior Belt Washing System That
Provides The Highest Degree in Belt
Cleaning Technology*

Click for More Information

For more information and benefits of the ASGCO Wash Box contact us at www.asgco.com



Fully enclosed to provide excellent cleaning while containing the wash waste fluid.



Removable inspection door on each side, with wash down hose included.

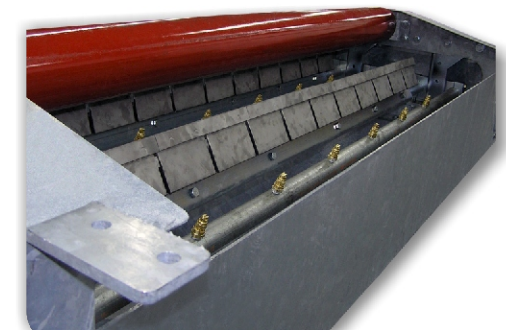

Each steel enclosed box is equipped with a combination of pressure rollers, spray bars and Razor-Back belt cleaners.