

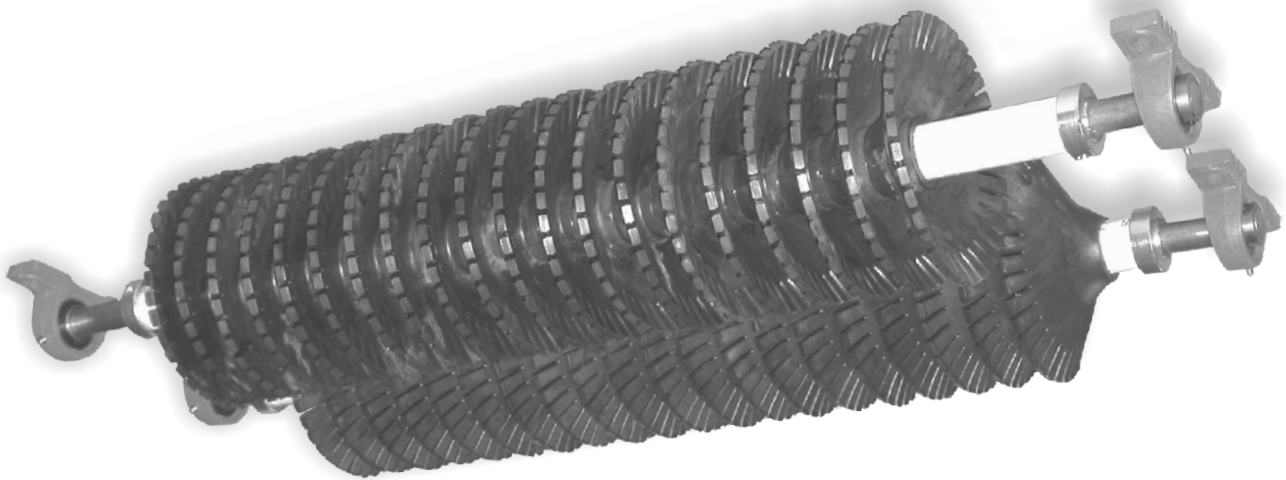

CHEVRON BELT CLEANERS

INSTALLATION, OPERATION & MAINTENANCE INSTRUCTIONS



Check us out at
www.asgco.com

Customer Service
800-344-4000



24 Hour Emergency
Service and Parts
610-821-0210



ASGCO Mfg., Inc.
301 Gordon Street
Allentown, PA 18102
610-821-0216
FAX 610-778-8991

Important Safety Notice

Always observe the basic rules of safety when working with any conveyor system. To avoid injury and equipment damage, be sure that all controls to the conveyor are locked out and the power source is disconnected at all times during installation.

Installation Tools

In addition to the items provided by ASGCO, the following will be needed to install the Chevron Cleaner:

1. Heavy duty file
2. Drill with 1" and ½" bits
3. Cutting or burning equipment
4. Adjustable wrench
5. Tape measure
6. Carpenter's square
7. Straight edge
8. Allen wrench set

To ensure the most efficient cleaning operation possible, ASGCO supplies a wide range of Chevron assemblies.

ASGCO Chevron Cleaners:

SOLID or NOTCHED

- Solid version could have 6", 8" or 10" diameter discs
- Notched version is only supplied with 8" diameter discs
- Custom-made shafts in various lengths and with a varying number of discs

Selecting a location for the Chevron

The Chevron assembly is designed to remove the fine carryback material. When choosing a mounting location for the Chevron, it is important to consider the space available. The Chevron assembly can be mounted on the arc of a pulley or any section of the belt that is flat and tight.

The belt length required is determined by the diameter of the discs and the number of shafts. The following chart provides the distance in inches required to install the various assemblies.

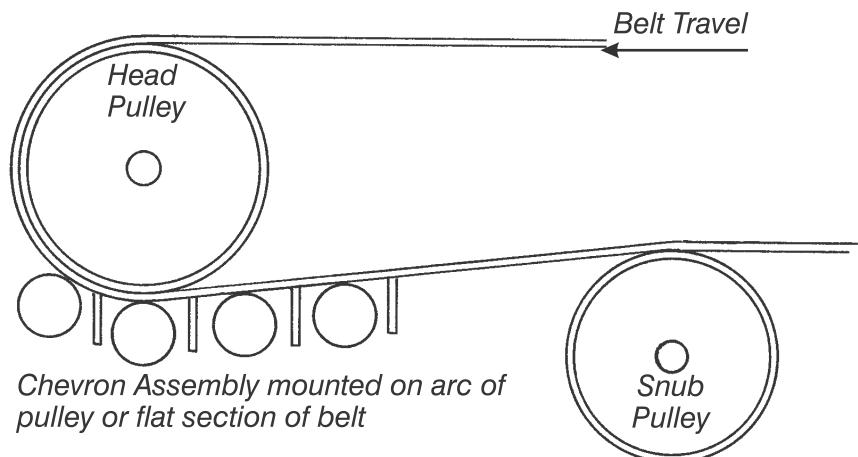

Disc Diameter	Four Assembly	Three Shaft Assembly	Two Shaft Assembly
10"	57"	43"	29"
8"	50"	38"	26"
6"	43"	33"	23"

NOTE: *The center point of the last shaft must be at least 10" away from any pulley or idler that is mounted below the belt.*

It is also important that the mounting location is adequate to allow the scraped material to fall back into the main discharge chute or a dribble chute. To ensure sufficient flow of the scraped material down the chute, an unlined chute should have at least a 75° angle (to the horizontal); and UHMW plastic lined chute should have at least a 65° angle (to the horizontal).

BELT TENSION REQUIREMENTS - Because of the unique design of the Chevron, the shafts must be mounted in a flat, tight area of the belt. The Chevron cannot operate to its maximum effectiveness on a belt that is loose or bowed.

ADDING IDLERS OR PULLEYS - If a sufficient mounting location cannot be found between the head and snub pulleys, the Chevron can be located elsewhere, provided that the proper steps have been taken to prevent the belt from loosening or troughing in the contact area. This can be done by mounting standard return idlers or small pulleys above the belt.

FABRICATING MOUNTING PLATES - If a chute is not present in the desired mounting location, mounting plates can be fabricated to simulate the sides of the chute and provide a mounting base for the Chevron shafts. These plates are made from 1/4" to 3/8" flat stock steel and should measure 12" to 16" high. Extend the plates the length of the Chevron installation, with an extra 6" on each end. Once a suitable mounting location has been chosen, the initial setup work can begin. Proceed as follows:

Initial Setup

1. The first measurement will vary, depending on the disc diameter and the size of the bearings within the pillow blocks:
 - A. IF USING 6" DISCS WITH 1" BEARINGS, measure the distance to a point 6" down from (perpendicular to) the belt on the chute wall. Mark this point "X".
 - B. IF USING 8" DISCS WITH 1" BEARINGS, measure the distance to a point 6 1/2" down from (perpendicular to) the belt on the chute wall. Mark this point "X".
 - C. IF USING 8" DISCS WITH 1 3/8" OR 1 1/2" BEARINGS, measure the distance to a point 7" down from (perpendicular to) the belt on the chute wall. Mark this point "X".

D. IF USING 10" DISCS WITH 1-3/8" OR 1-1/2" BEARINGS, measure the distance to a point 8" down from (perpendicular to) the belt on the chute wall. Mark this point "X".

- Transfer point "X" to the other side of the chute wall, making sure that the two marks are in the exact same location on both sides. These marks represent the location points of the mounting bracket bolt of the last Chevron shaft. Keep in mind that they must be at least 10" away from any pulleys or idlers mounted below the returning belt.

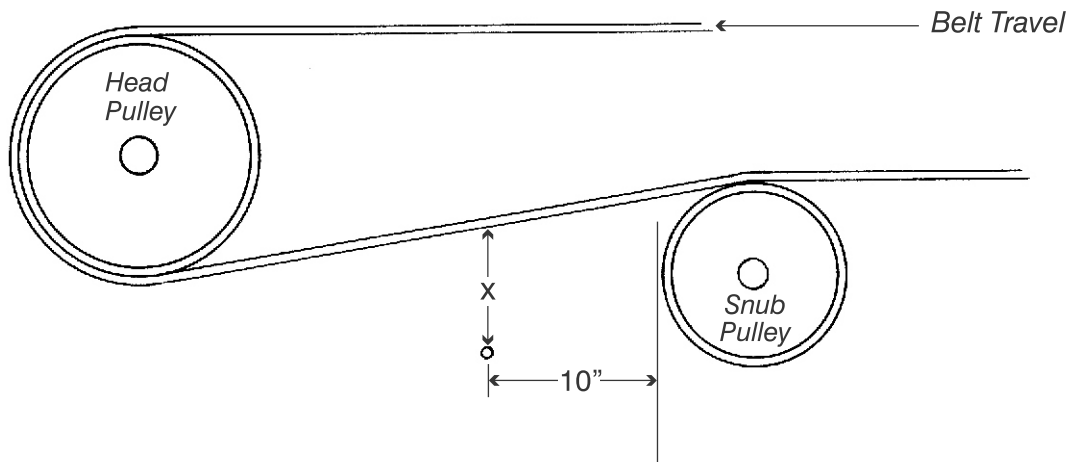

- Use the illustration to determine the center to center distance of the remaining Chevron bracket mounting points. The distance between mounting points is determined by the diameter of the Chevron discs. 10" diameter discs require a 14" center to center distance between mounting points. 8" diameter discs require a 12" center to center distance. 6" diameter discs require a 10" center to center distance. While moving towards the head pulley, mark the remaining mounting point locations on both chute walls with "X" marks as was done in Step 1, following the course of the belt for the distance that the Chevron's will be mounted.

- On both chute walls, scribe a line parallel to the belt and connecting each of the "X" end points. The intersecting points are the mounting points for the Chevron assembly and must be identical on both chute walls.

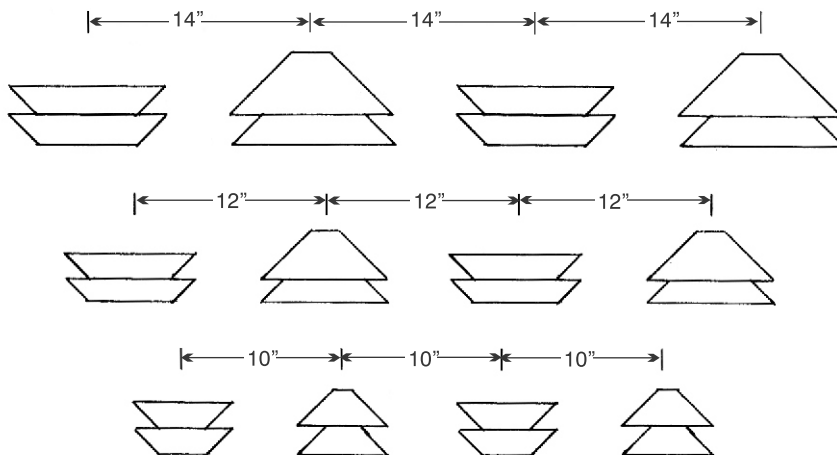

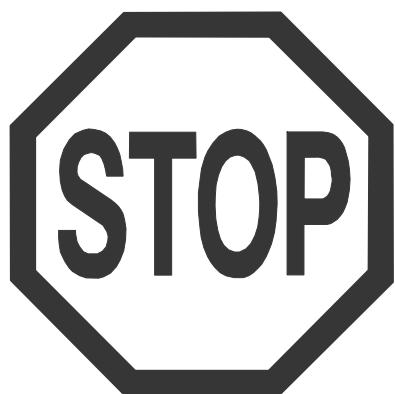

IMPORTANT

**For brackets mounted *INSIDE*
the chute wall go to Page 6**

**For brackets mounted *OUTSIDE*
the chute wall go to Page 7**

5. Burn or drill a 1" diameter hole at each of the "X" points on both chute walls.
6. Insert a 3/4" x 2" long bolt into each of the 1" diameter holes. Be sure to insert the bolts from the outside of the chute wall, then place a nut and washer on each bolt from the inside. Only hand tighten the nuts at this time.
7. Tack weld the heads of each of the bolts on both sides of the chute wall.

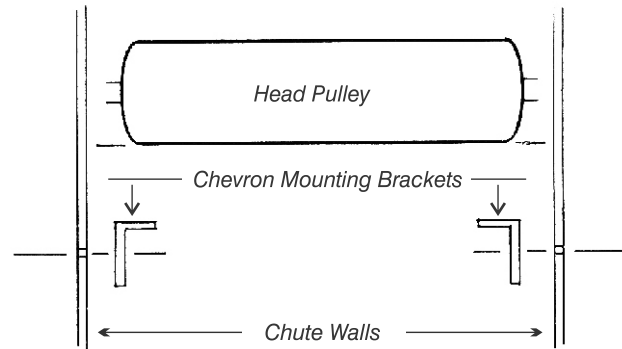

Chevron Installation

When all of the bolt heads have been welded, the Chevron installation can begin. Start with the last shaft installation and work forward toward the head pulley.

1. Install a Chevron mounting bracket on each of the bolts. To do this, loosen the nut, slide the bracket into position, then snug up the nut by hand tightening. Be sure that the top of the bracket (the part with two notches) is facing up as shown.

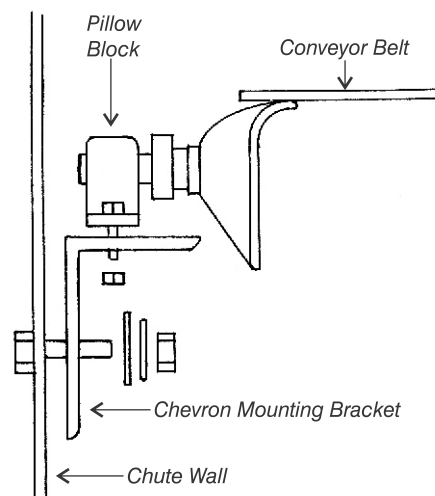

2. Position a Chevron shaft on top of the facing mounting brackets. (The pillow block and bearing are shipped already mounted on the shaft.) Fasten both pillow blocks to the bracket with 3/8" X 1 1/2" long bolts and hardware (flat washer, locking washer, and nut). [Don't worry about the direction of the discs at this point.]

GO TO PAGE 9

5. The next measurement also varies, depending on the outside diameter of the Chevron shaft:
 - A. IF THE OUTSIDE DIAMETER OF THE SHAFT IS 1", use a soapstone and straightedge to scribe a vertical line 1½" up from each of the "X" end points. Mark each of these end points "N".
 - B. IF THE OUTSIDE DIAMETER OF THE SHAFT IS 1½", use a soapstone and straightedge to scribe a vertical line 1¾" up from each of the "X" end points. Mark each of these end points "A".
6. Scribe a horizontal line 2½" long, with its center intersecting point "A", on both chute walls. Mark the end points of these lines "A1" and "A2".
7. Scribe vertical lines from points "A1" and "A2" to the top of each chute wall.
8. Repeat this marking procedure on the remaining "X" points on both chute walls.
9. Burn or drill a 1 diameter hole at each of the "X" points on both chute walls.
10. Burn or cut along the horizontal and vertical lines scribed in Steps 6-8. Remove the chute wall material; the result will be rectangular cutouts above each 1 diameter hole.
11. Insert a ¾" x 2" long bolt into each of the 1" diameter holes. Be sure to insert the bolts from the inside of the chute walls. Place a flat washer, lock washer, and nut on each bolt. Only hand tighten the nuts at this time.
12. Tack weld the heads of each of the bolts on the inside of the chute walls.

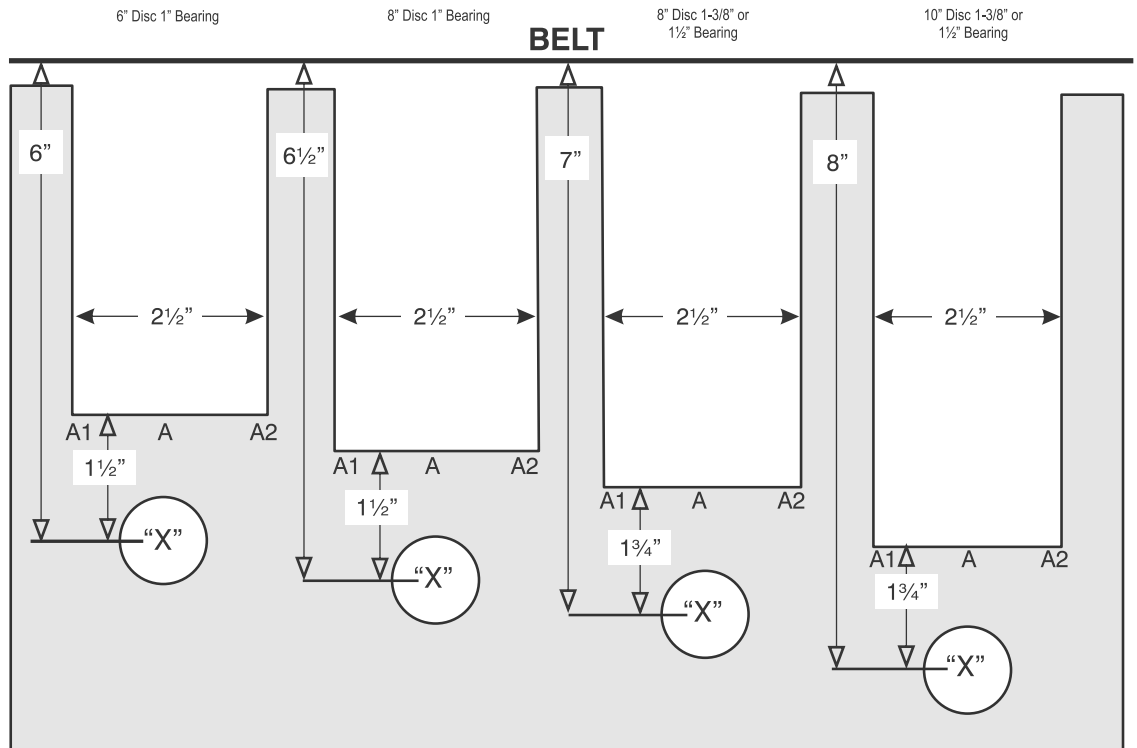

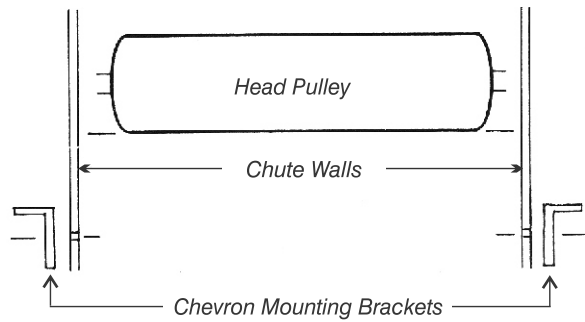

Chevron Installation

When all of the bolt heads have been welded, the Chevron installation can begin. Start with the last shaft installation and work forward toward the head pulley.

1. Install an Chevron mounting bracket on each of the bolts. To do this, loosen the nut, slide the bracket into position, then snug up the nut by hand tightening. Be sure that the top of the bracket (the part with two notches) is facing up as shown.
2. Flats must be filed at the set screw locations on the end of the Chevron shaft. To do this, position the shaft inside the pillow block and remove the two set screws using an Allen wrench. Insert a punch into the set screw holes and mark their positions on the shaft. Replace the set screws and remove the shaft from the pillow block, and file the flats as indicated by the marks.

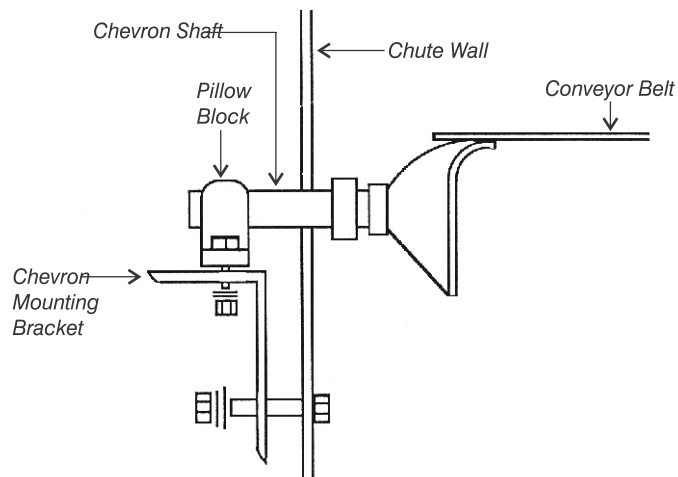

3. Position one end of the shaft, then the other, through the rectangular cutouts in the chute wall.
4. Slide the pillow blocks over the shaft with the flats facing the set screws. Tighten the set screws with an Allen wrench.
5. Fasten both pillow blocks to the bracket with $\frac{3}{8}$ " x $1 \frac{1}{2}$ " long bolts and hardware (flatwasher, locking washer and nut).

To adjust the Chevron to its proper cleaning pressure, push both Chevron mounting brackets up until the discs start to compress against the belt. Run your hand across the top of the Chevron where it touches the belt and bend all of the discs in the same direction. Stop adjusting upwards on the brackets when there is a 1/16" to 1/8" gap between the discs across the width of the belt.

Note: Make sure gap is measured on top of Chevron, NOT on base belt.

1/16" to 1/8" gap between discs when they are compressed against the belt.

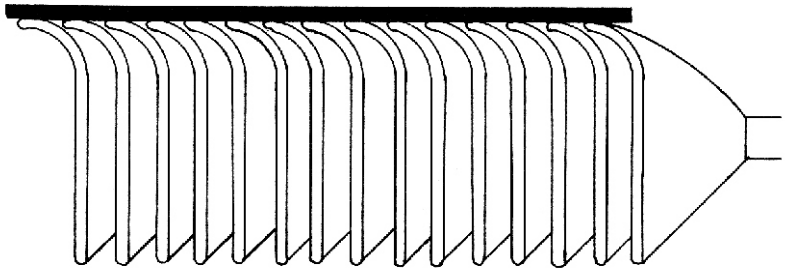

Note: the 1/8" gap should be measured with solid or notched disc on surface of a Chevron.

CAUTION: Over-adjustment of the Chevron against the belt will result in premature wear and under-adjustment will result in poor cleaning action. Do not allow the discs to touch each other when bending them into position.

When the Chevron has been properly adjusted, tighten the two nuts with a slugger wrench so that vibration during operation will not cause the adjustment to be altered.

Install a bearing cover on each bearing by stretching the 4" X 14" Neoprene sheet over the top and under the pillow block. Secure the cover by using the bottom bolt extensions as locating pins. The bolts should protrude through the holes in the Neoprene.

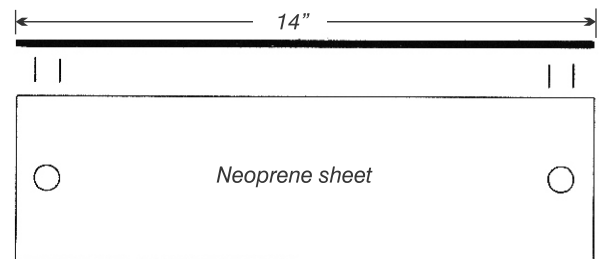
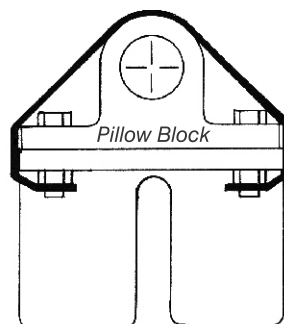

Vibro Band and Bearing Cover Installation

Before installing the remaining Chevron shafts, the Vibro Band must be located and installed on this shaft. Proceed as follows:

1. Position a Vibro Band mounting bracket on each side of the chute wall. The bracket should be located with its top edge approximately 1" below the belt and perpendicular to the ground (not the belt). The notched end of the bracket should face up toward the belt and the center of the chute.

IMPORTANT: There should be a 2" distance between the Vibro Band mounting bracket and Chevron discs.

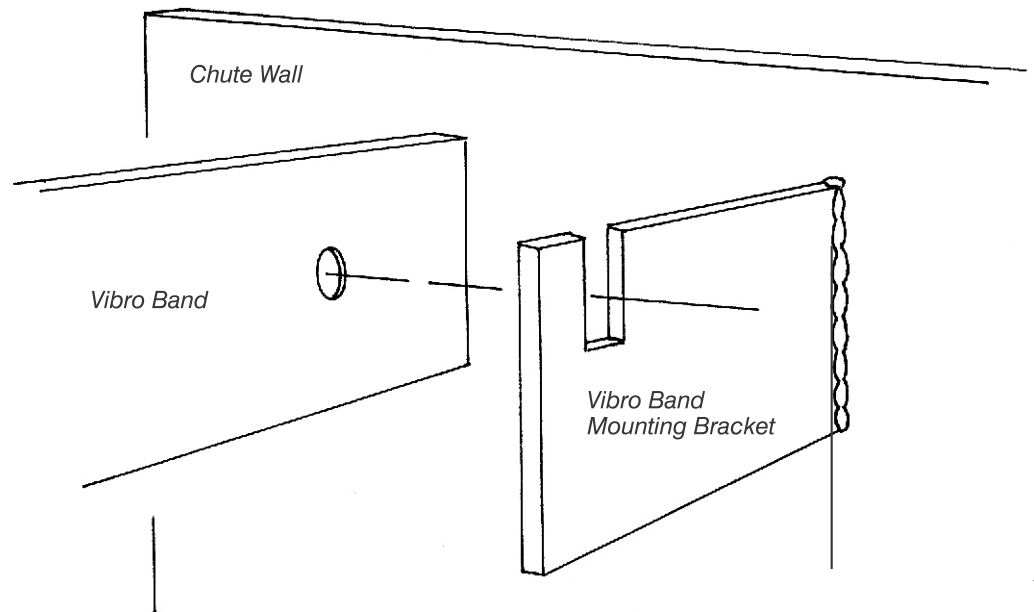

2. Weld the Vibro Band mounting brackets into position.
3. Take one of the Vibro Bands and hold it up to but not touching the belt while resting it against the front of the brackets. From the back, mark the two slot locations on the plastic. Drill a $\frac{1}{2}$ " diameter hole at the bottom of the slot location on each side.
4. Install the Vibro Band on the side of the mounting bracket facing the head pulley with two $\frac{3}{8}$ " X 1" long bolts and hardware. Adjust it so that it just kisses the belt across the full width.

CAUTION: The Vibro Bands do not provide cleaning action; their function is to direct the scraped material away from the next Chevron and direct it down into the chute. Adjusting the Vibro Bands too tightly will cause premature wear.

The second shaft is installed with all of the discs bending in the opposite direction. Continue to alternate the direction of the discs in each subsequent shaft installation.

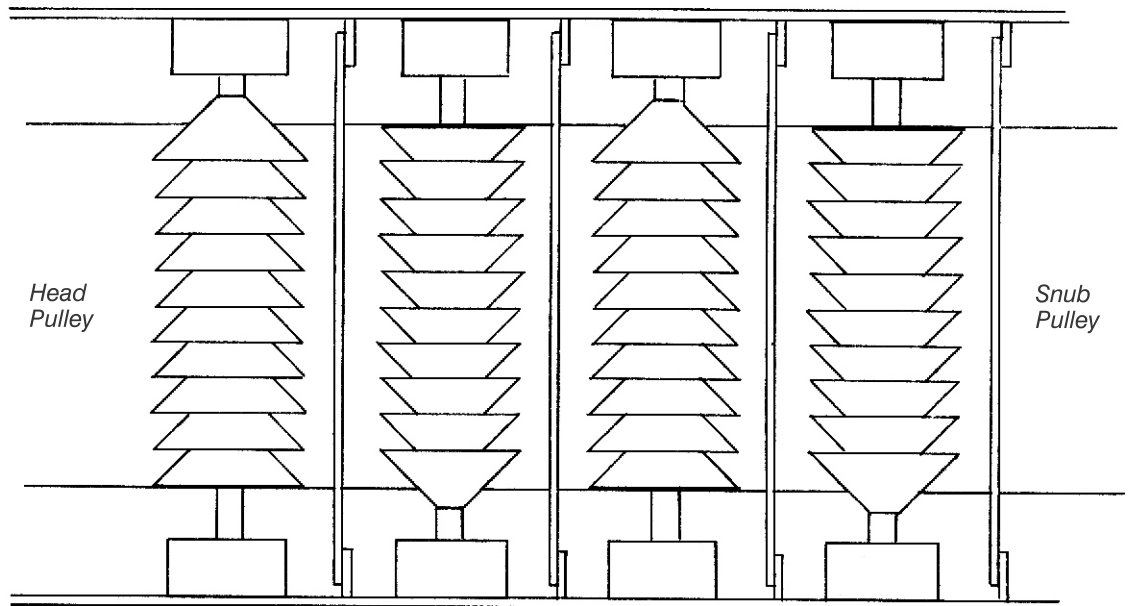

Move on to the next Chevron shaft installation, using this same step-by-step procedure. Remember that the direction of the discs must be alternated on each subsequent installation.

Maintenance

- When used in a 24-hour operation, the Chevron must be adjusted every four months. Grease hoses should be installed if the Chevron mounting location prevents easy lubrication.
- Grease the bearing periodically.
- Operation of the conveyor belt without material should be kept to a minimum.

Information

Key	Description	Part Number
1	Shaft Assembly w/o Bearings	Call Customer Service w/original part number of cleaner
2	Bearing - 1" Diameter	ASG-FOD-BR1
	Bearing - 1½" Diameter	ASG-FOD-BR2
3	Mounting Bracket for 1" Bearing	ASG-FOD-MB1
	Mounting Bracket for 1.5" Bearing	ASG-FOD-MB2
4	Disc 8" Diameter - Notched 1" Shaft	ASG-FOD-8.0D-N
	Disc 8" Diameter - Notched 1.5" Shaft	ASG-FOD-8.5D-N
	Disc 6" Diameter - Plain 1" Shaft	ASG-FOD-6.0D
	Disc 8" Diameter - Plain 1" Shaft	ASG-FOD-8.0D
	Disc 8" Diameter - Plain 1.5" Shaft	ASG-FOD-8.5D
	Disc 10" Diameter - Plain 1.5" Shaft	ASG-FOD-10.5D

Call your ASGCO Distributor for any questions or replacement parts

Components Diagram

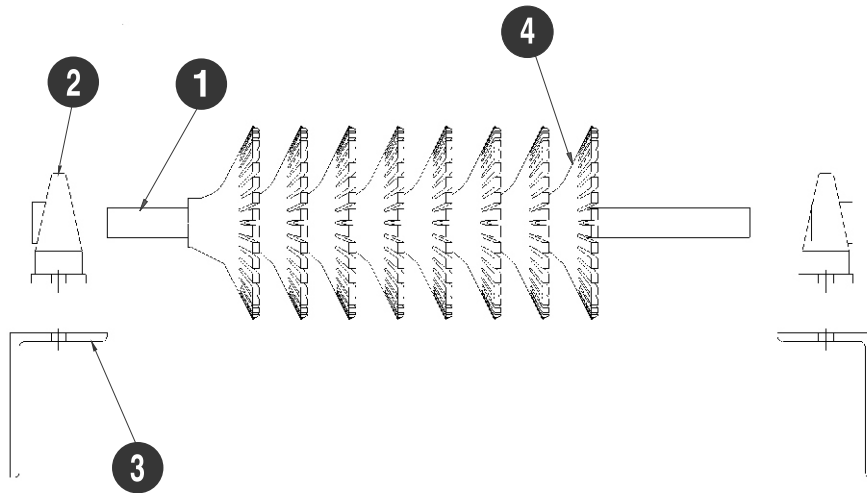

- 1** Shaft assembly -
includes shaft, spacers,
discs and collars
- 2** Bearing - specify 1" diameter
specify 1.5" diameter
- 3** Mounting Bracket
- for 1" bearing
- for 1.5" bearing
- 4** 8" notched 1" shaft
8" notched 1.5" shaft
6" plain 1" shaft
8" plain 1" shaft
8" plain 1.5" shaft
10" plain 1.5" shaft